

# User Manual

# **OPTI-Solar**

**Solar Inverter for Water Pump  
SP15000 Revival Series**

# Table Of Contents

<b>ABOUT THIS MANUAL .....</b>	<b>1</b>
Purpose.....	1
Scope.....	1
<b>SAFETY INSTRUCTIONS.....</b>	<b>1</b>
Inspection.....	1
Installation.....	1
Operation .....	2
Maintenance .....	2
<b>INTRODUCTION .....</b>	<b>3</b>
Features.....	3
Basic System Architecture .....	3
Product Overview.....	4
<b>INSTALLATION .....</b>	<b>5</b>
Unpacking and Inspection.....	5
Preparation .....	5
Mounting the Unit.....	5
PV Connection .....	6
AC Output (Motor) Connection .....	7
Final Assembly.....	8
Control Signal Connection (Optional) .....	9
<b>COMMISSIONING .....</b>	<b>10</b>
<b>OPERATION.....</b>	<b>11</b>
Power ON/OFF .....	11
Operation and Display Panel.....	11
Parameter Setting.....	13
<b>Fault and Warning Code .....</b>	<b>18</b>
Fault Reference Code.....	18
Warning Reference Codes.....	19
<b>SPECIFICATIONS.....</b>	<b>20</b>

# ABOUT THIS MANUAL

## Purpose

This manual describes the assembly, installation, operation and troubleshooting of this unit. Please read this manual carefully before installations and operations. Keep this manual for future reference.

## Scope

This manual provides safety and installation guidelines as well as information on tools and wiring.

# SAFETY INSTRUCTIONS



**WARNING: This chapter contains important safety and operating instructions. Read and keep this manual for future reference.**

## Inspection



If missing components or damaged inverter is found after receiving, please do NOT install or operate it. Otherwise, it may cause human injury or equipment damage.

## Installation



1. Before installation, please make sure if the voltage range of PV panel meets the requirement.
2. Check if all wires are firmly connected without short circuit. Otherwise, it will cause equipment damage.
3. Do NOT install this inverter under direct sunlight because high temperature may cause equipment damage.
4. Please install the inverter away from inflammable and explosive objectives. Please ensure no liquid can enter the inverter.
5. Please install the inverter on metal non-combustible surface.



1. **CAUTION!!** Only qualified personnel can install and operate this inverter.
2. To reduce risk of electric shock, disconnect power source before making wire connection. Otherwise, it may cause electrical shock.
3. To reduce risk of electric shock, NEVER touch any terminals on electric circuits.
4. If connection cable between inverter and water pump is more than 50m, please be sure to install a three-phase AC reactor. Inductance value for each phase is about 1mH. Otherwise, water pump would be easily to be damaged.

## Operation



1. Only after wire connection is complete and put cover back to the inverter, it's ok to do commissioning. Otherwise, it will cause electric shock
2. If sunlight is sufficient but little water is pumped, maybe the wires on motor connection are reversely connected. Please reverse any two wires of them.
3. When testing water pump, be sure to install water pump at appropriate water level. Never allow water pump in dry running. Otherwise, the inverter will activate protection.

## Maintenance



1. Only qualified personnel can maintain, repair, inspect the inverter and replace any components.
2. It may still contain energy after disconnecting power source for 10 minutes. Only service the unit after the bus voltage is within safe range.

# INTRODUCTION

Interest in renewable energy has increased over the past few years due to solar power becoming more cost effective and eco-friendly. This is a solar inverter which allows power to be switched from the DC power obtained from solar panels to the AC power needed to control the pump. With the renewable solar inverter, pumps can adapt to solar power sources rather than traditional electrical supplies or generators.

This solar inverter is built-in with MPPT solar charger to maximize solar power. Besides, it is easy to install with low maintenance cost. It becomes an eco-friendly solution for the rural areas where grid power is expensive and unreliable.

## Features

- Built-in MPPT solar charger
- Supports three-phase asynchronous motor
- Built-in full protection and self-diagnosis
- Soft start function prevents water hammer effect and extends system lifecycle
- Comprehensive LED display screen and indicators for real-time system status
- Remote monitoring through RS-485

## Basic System Architecture

This solar inverter is specially designed to power water pump. The following illustration shows basic application for this inverter. It also includes PV modules and remote float switches to have a complete running system.

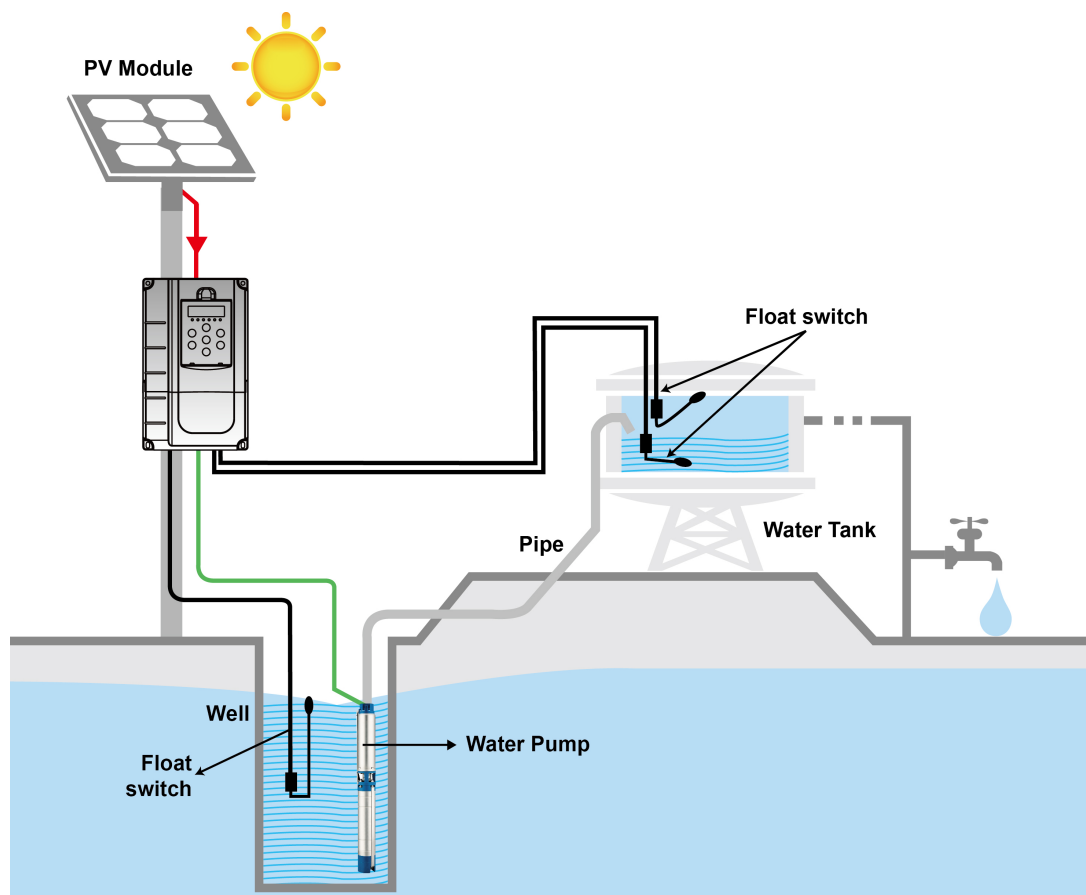

## Product Overview

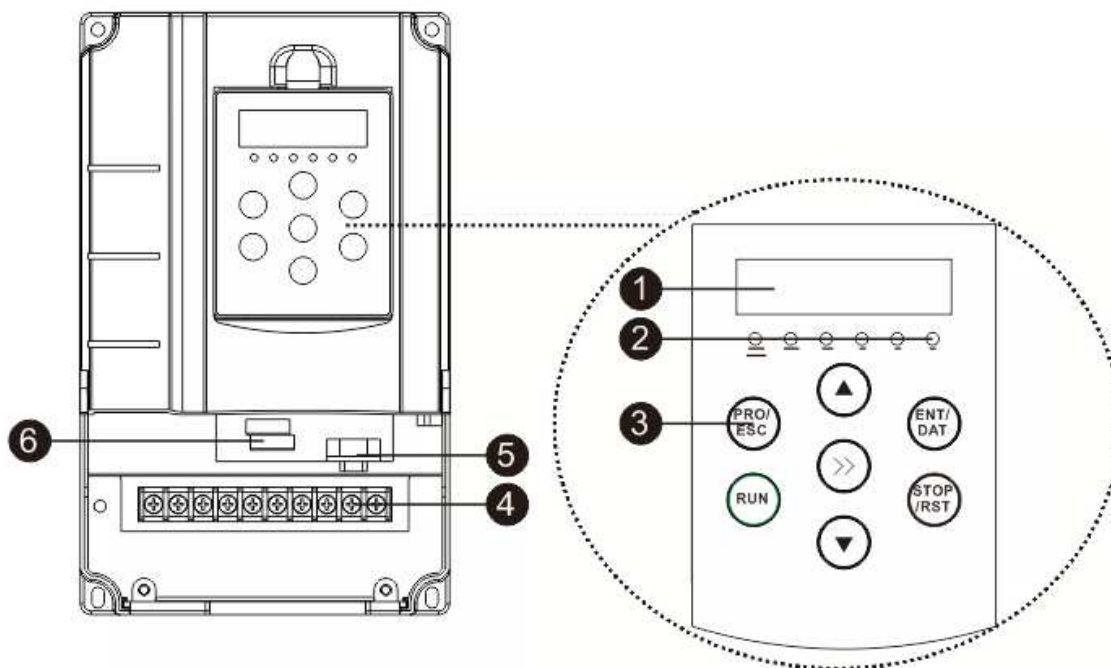

1. Display screen (Refer to Operation and Display Panel for the details)
2. LED indicators (Refer to Operation and Display Panel for the details)
3. Operation buttons (Refer to Operation and Display Panel for the details)
4. Input and output terminals
5. RS-232 communication port
6. Control signal terminals

# INSTALLATION

## Unpacking and Inspection

Before installation, please inspect the unit. Be sure that nothing inside the package is damaged. You should have received the following items inside of package:

- The unit x 1
- User manual x 1
- RS-232 cable x 1

## Preparation

Before connecting all wirings, please open bottom cover and pull up wiring cover.

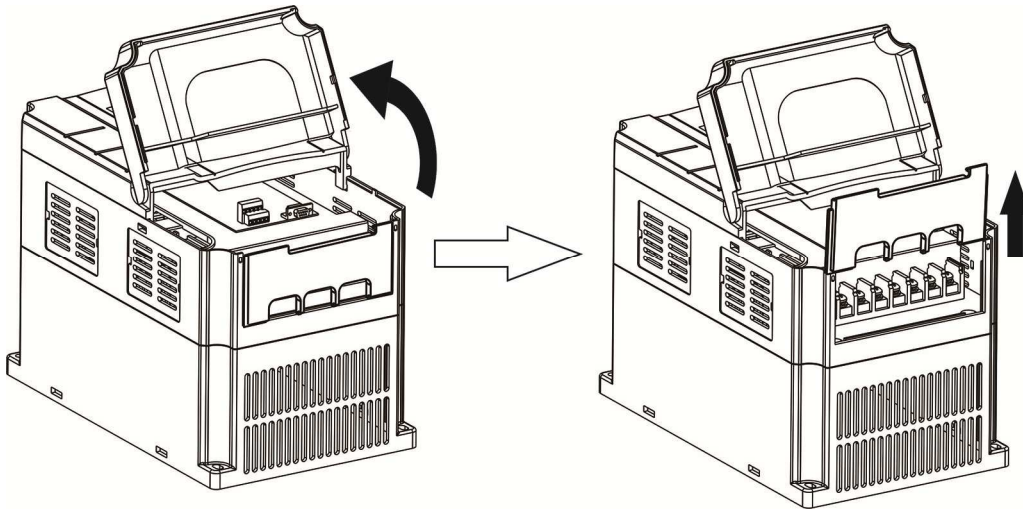

## Mounting the Unit

Consider the following points before selecting where to install:

- Do not mount the inverter on flammable construction materials.
- Mount on a solid metal surface.
- Avoid direct sunlight. Be sure the environment is shady and cool.
- Be sure to install the inverter into a box with waterproof and dustproof.
- Install this inverter at eye level in order to allow the screen display to be read at all times.
- The recommended installation position is to be adhered to the wall vertically.
- Be sure to keep other objects and surfaces as shown in the diagram to guarantee sufficient heat dissipation and to have enough space for removing wires.

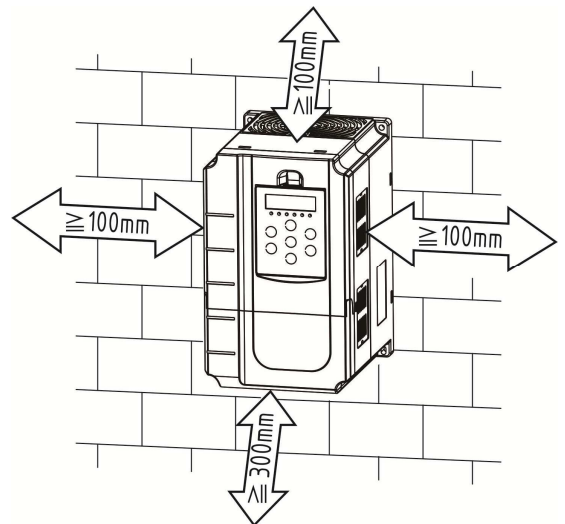

**SUITABLE FOR MOUNTING ON CONCRETE OR OTHER NON-COMBUSTIBLE SURFACE ONLY.**

1. Drill four holes in the marked locations with four screws.

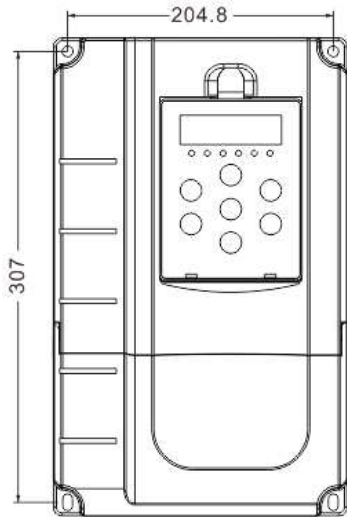

2. Install the unit by screwing four screws. It's recommended to use M5 screws.

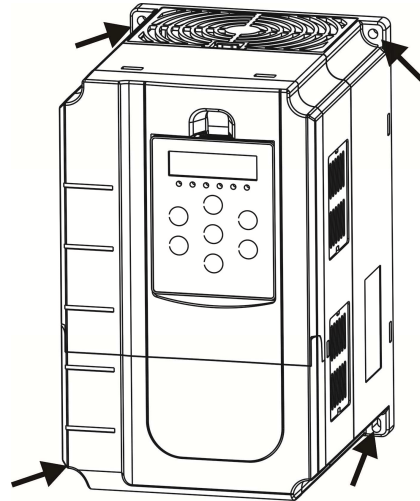

## PV Connection

**CAUTION:** Before connecting to PV modules, please install **separately** a DC circuit breaker between inverter and PV modules. The recommended spec of DC breaker is C63A/2P/1000VDC/25KA for 15KW.

NOTE: It's required to install PV combiner box when using several PV modules in parallel and series.



### **CAUTION: Important**

Before making PV connection, be sure to do the following actions to prevent human injury or machine damage.

1. It's required to turn off circuit breaker.
2. Make sure connect positive pole (+) of PV input connector in inverter to positive pole (+) of PV modules and negative pole (-) of PV input connector in inverter to negative pole (-) of PV modules.



**PV Module Selection:**

When selecting proper PV modules, please be sure to consider below parameters:

1. Open circuit Voltage (Voc) of PV modules not exceeds max. DC voltage (800VDC).
2. Accumulated voltage of connected PV panels should be close to 560V for inverter with 380V output voltage.

To calculate PV module numbers in series (N) and in parallel (M), please follow below formula:

- $Imp > Po / (Kvo \times 0.9 \times M)$   
Po represents the rated output power.  
Kvo is equal to 560V/585/606V/642V for 380V/400V/415V/440V output voltage respectively.
- Maximum PV module numbers in series (N)  $> 560 / Vmp$

We strongly recommend the total PV Vmp is around 560Vdc to get the optimum MPPT output.

Below are popular solar panel specifications in the market:

- A. 140-A: 140W, Vmp=17.9V, Imp=7.82A, Voc=22.0V
- B. 250-A: 250W, Vmp=30.64, Imp=8.16A, Voc=37.38V

Inverter model	15KW
PV Panel 140-A	32 pieces in Series x 4 Strings (17920W PV Panels)
PV Panel 250-A	19 pieces in Series x 4 Strings (19000W PV Panels)

**AC Output (Motor) Connection**

**WARNING!** All wiring must be performed by a qualified personnel.

**WARNING!** It's very important for system safety and efficient operation to use appropriate cable for AC output connection. To reduce risk of injury, please use the proper recommended terminal and cable size as below.

**Recommended terminal types:**

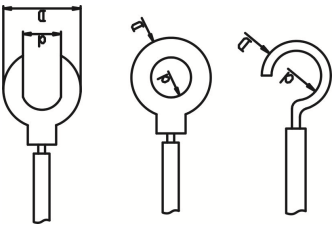

**Suggested cable requirement:**

Model	Typical Amperage	Wire size	Terminal		Torque Value
			Dimensions		
			d (mm)	D (mm)	
15KW	29A	8 AWG	4.5	9.5	1.3 ~ 1.4 Nm

Please follow below steps to implement motor connection:

1. Remove insulation sleeve 10mm for three conductors. And shorten three conductors 3 mm.
2. Insert wires according to polarities indicated on terminal block and tighten the terminal screws.

**NOTE:** To reverse the direction of motor rotation, reverse any two wires.

US	Black (BLK)	Red (RED)	Yellow (YEL)	Ground (GND)
International	Gray (GRY)	Black (BLK)	Brown (BRN)	Ground (GND)

International standards for motor lead wire

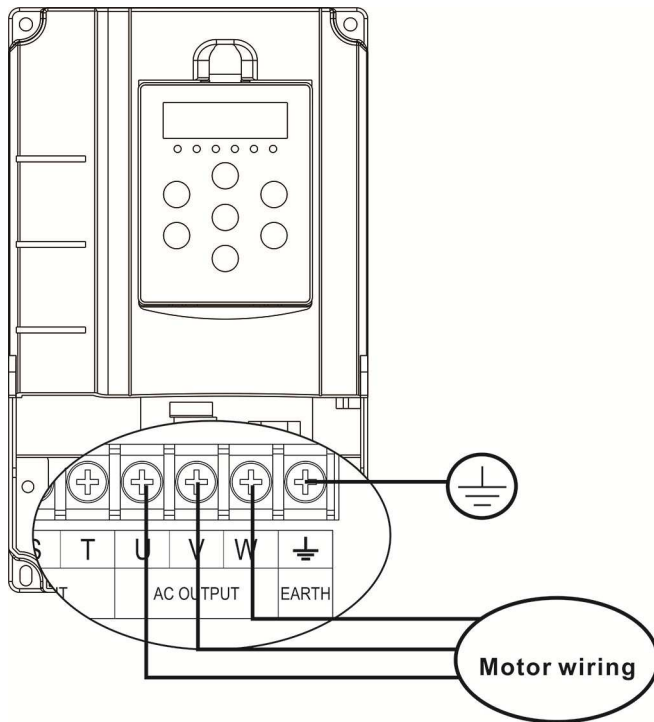

3. Make sure the wires are securely connected.

## Final Assembly

After connecting all wirings, please put bottom cover back and push back wiring cover to the original position as shown below.

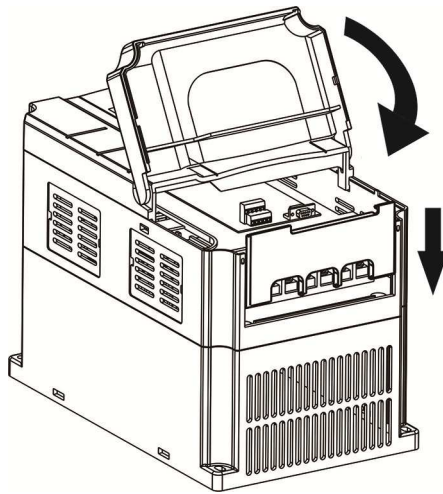

# Remote Communication and Signal Connection

Wiring terminals of communication and signal ports are listed below:

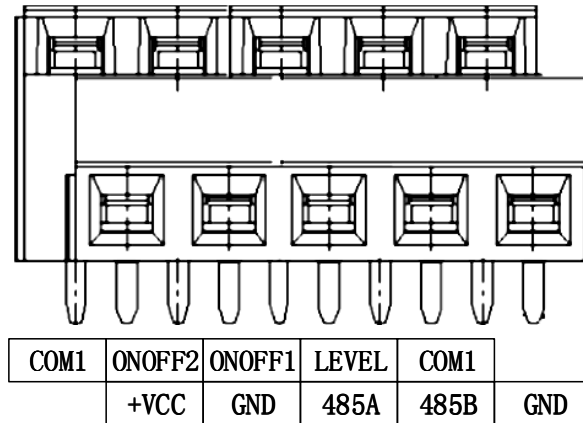

## Communication Connection

**WARNING:** Please do NOT mis-connect the wires between the inverter and RS485/RS-232 converter.

First, please use one RS485 to RS 232 converter as media converter between inverter and computer. Please follow below chart for wiring connection between RS485 on the inverter and media converter. It's necessary to connect to the utility as power source for the media converter. Then, use supplied RS-232 cable to connect to converter and computer. After wiring is complete, the media converter will light on and any data transmission occurs, the indicators for RXD and TXD will flash.

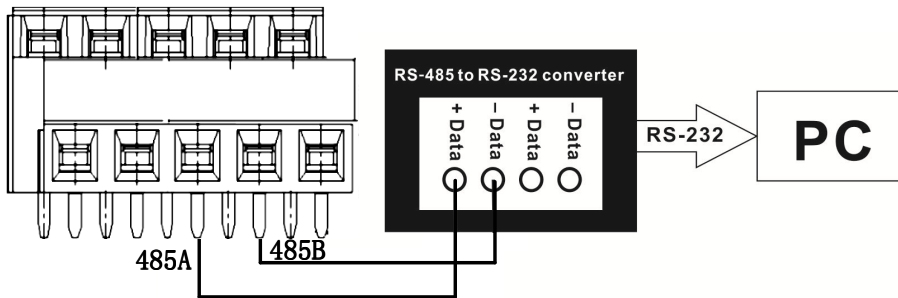

## Control Signal Connection (Optional)

There are 5 ports in control signal terminals. It is to detect water level to prevent water pump from dry running and water tank from overflow/underflow.

Control Signal Port:

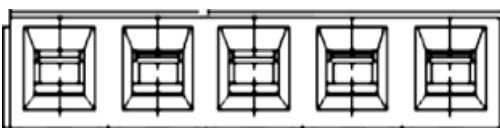

COM1	ONOFF2	ONOFF1	LEVEL	COM1
Remote Float Switch(1)		Remote Float Switch(2)		

Internal circuit:

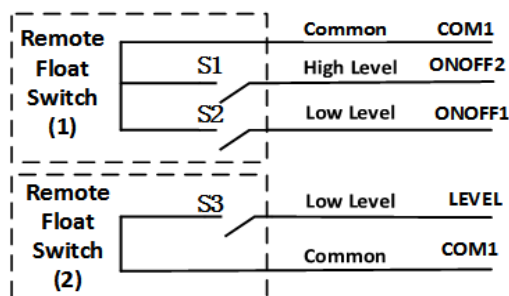

## Signal Port Status

Signal Water level status	Remote Float Switch (1)		Remote Float Switch (2)
	S1	S2	S3
Normal Level	Open	Open	Close
Low Level	Open	Close	Open
High Level	Close	Open	n/a

### Remote float switch (1):

It's to prevent water tank overflow or underflow by sensing a remote float switch in water tank. When water level is normal, it will keep ONOFF1 & COM1 and ONOFF2 & COM1 in open status. When water level is high in water tank, it will receive high-level signal (open status on ONOFF1 & COM1 and closed status on ONOFF2 & COM1) from float switch and stop the inverter. When water tank is in low level, it will receive low-level signal (closed status on ONOFF1 & COM1 and open status on ONOFF2 & COM1) from float switch and start up the inverter. This action is only available when the auto turn-on function is enabled. If the water level is normal, ONOFF1 & COM1 are normally in open status.

### Remote float switch (2):

It's to prevent the water pump dry running by connecting to remote float switch. The length of connecting wire should not longer than 50m. If the water level is normal in the well, COM1 and LEVEL (S3) is kept in normal close status. If the water level is low in the well, COM1 and LEVEL (S3) will be open status. If this port is not connected to water level probe, be sure to connect COM1 and LEVEL together. It's default setting from factory.

## COMMISSIONING

Step 1: Check the following requirements before commissioning:

- Ensure all wires are firmly and correctly connected
- Use a megger to check insulation of motor and wires
- Check if the open circuit DC voltage of PV module meets requirement

Step 2: Switch on DC breaker and provide power to the inverter. Then, display screen will show 0.00. Please set up the parameters of the inverter such as rated power, rated frequency, rated current and rated voltage. For the detailed setting, please check "Parameter setting" section in Operation chapter.

Step 3: Press "RUN" button to activate the inverter. If the output water yield is low, it may be wrong for output wire connection. Please exchange any two wires connected to the motor. Please be sure the output frequency and water yield are normal. It means the wire connection is correct and complete.

# OPERATION

## Power ON/OFF

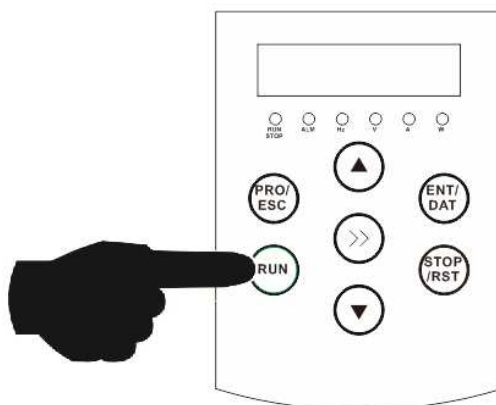

Once the unit has been properly installed, simply press "RUN" button (located on the button area) to turn on the unit.

## Operation and Display Panel

The operation and display panel, shown in below chart, is on the top case of the inverter. It includes six indicators, seven function buttons and a display screen, indicating the operating status, alarm status and input/output power information.

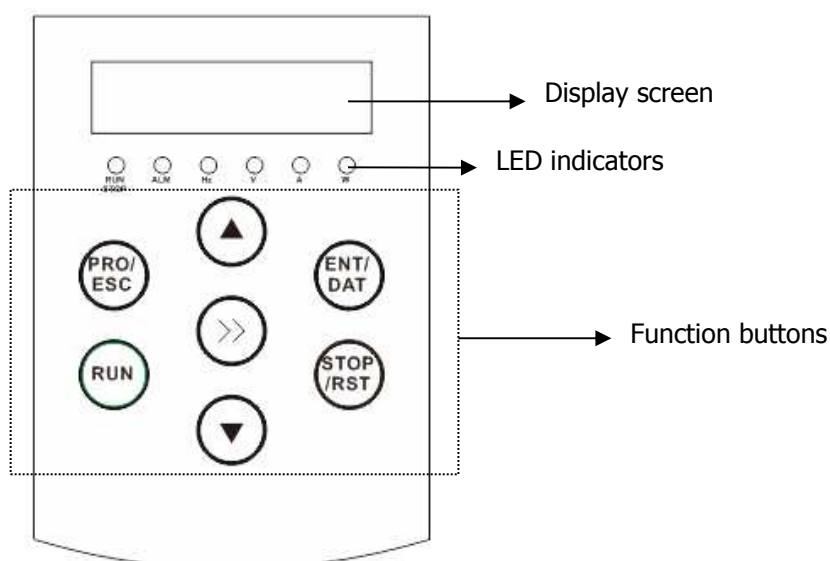

### LED Indicator

LED Indicator			Messages
Hz	Green	Solid On	Output frequency value is displayed on the display screen.
A	Green	Solid On	Output current value is displayed on the display screen.
V	Green	Solid On	Output voltage value is displayed on the display screen.
W	Green	Solid on	Output power value is displayed on the display screen.
ALM	Green	Solid on	The inverter is in fault or warning status.
STOP/RUN	Green	Solid on	The inverter is running.
	Green	OFF	The inverter stops.

**NOTE:** After the inverter is turned on, display screen will show the output frequency until it is stable. After the inverter is turned off, display screen will still show output frequency until it's 0.

### Function Buttons



Function Button	Description
PROG/ESC	To enter or exit setting mode.
ENTER/DAT	To confirm the selection/value in setting mode.
RUN	To turn on the unit, press this button for at least 1 second.
STOP/RST	<ul style="list-style-type: none"> <li>● To turn off the unit, press this button for at least 1 second.</li> <li>● To reset fault message, press this button for at least 1 second.</li> </ul>
▲	To increase the setting value.
▼	To decrease the setting value.
>>	<ul style="list-style-type: none"> <li>● To select modified bit of parameter in setting mode.</li> <li>● To cyclically switch displayed information when the inverter is off or in operation mode. The information sequentially is displayed as current output frequency, current output voltage, current output current, current PV voltage and current output power.</li> </ul>

# Parameter Setting

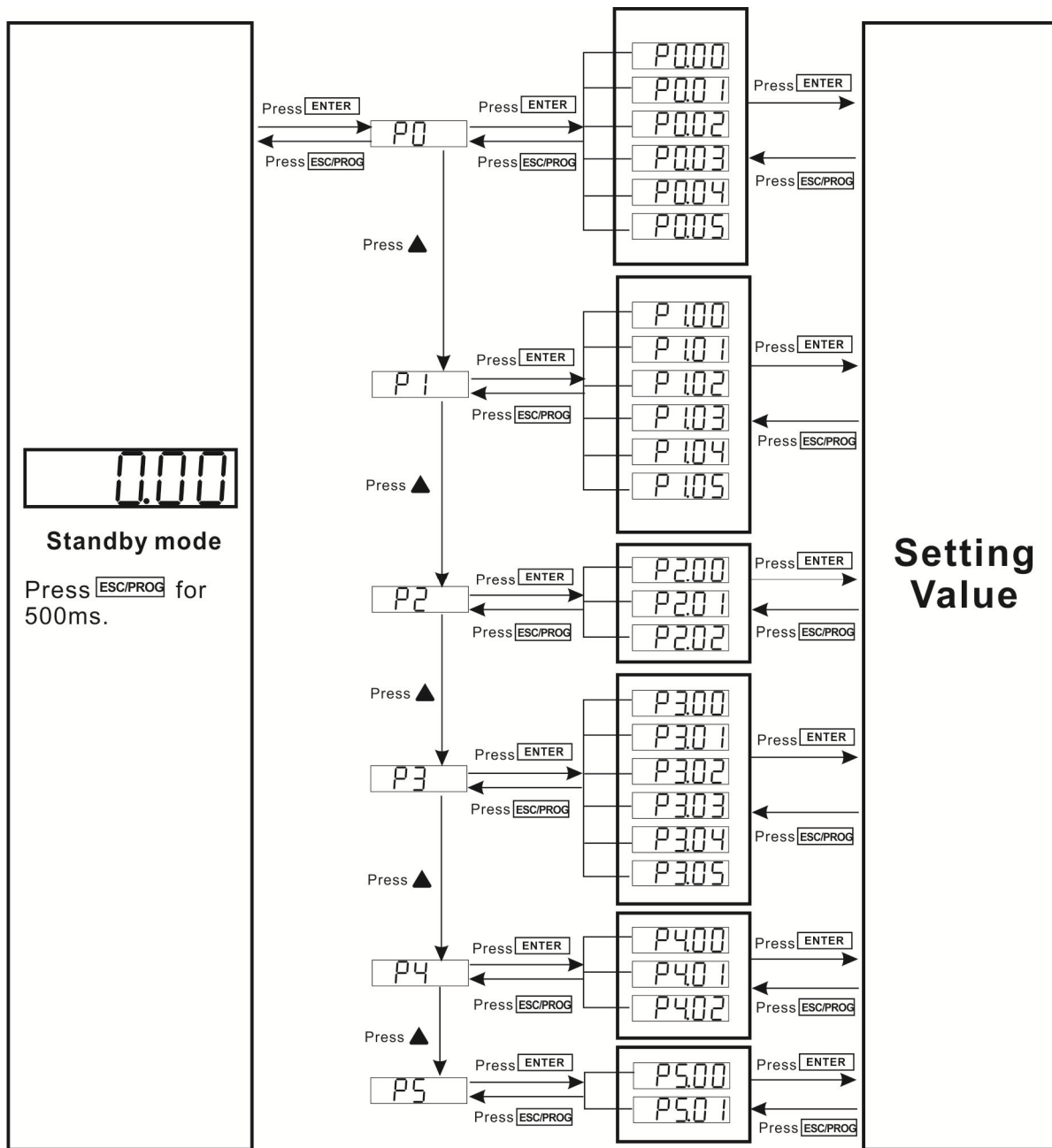
The entire display setting program structure is demonstrated as below chart.

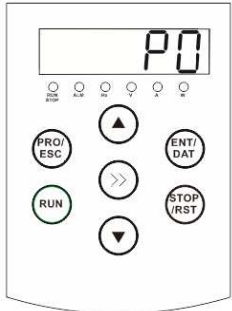
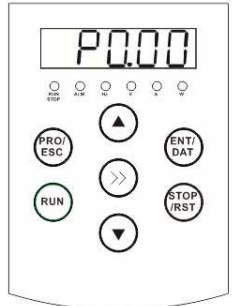
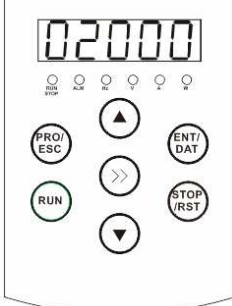
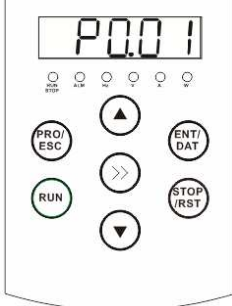

### Parameter setting procedure for water pump

Operation steps	Screen Display
<p>1. Quick press "ESC/PROG" button once. Then, it will display "P0" in display screen.</p>	 <p>The control panel features a digital display showing 'P0'. Below the display are six indicator lights labeled STOP, RUN, FAULT, and two others. The control buttons include PRO/ESC, ENT/DAT, RUN, and STOP/RST, along with directional arrows (up, down, left, right).</p>
<p>2. Quick press "ENTER" button once and display screen will show as in the right chart.</p>	 <p>The control panel features a digital display showing 'P0.00'. Below the display are six indicator lights labeled STOP, RUN, FAULT, and two others. The control buttons include PRO/ESC, ENT/DAT, RUN, and STOP/RST, along with directional arrows (up, down, left, right).</p>
<p>3. Press "ENTER" button again to start to set up rated power of the water pump. Press "&gt;&gt;" buttons to switch cursor location. Press "▲" or "▼" button to change value for rated power. Until it shows correct rated power, press "ENTER" button to confirm the setting.</p>	 <p>The control panel features a digital display showing '02000'. Below the display are six indicator lights labeled STOP, RUN, FAULT, and two others. The control buttons include PRO/ESC, ENT/DAT, RUN, and STOP/RST, along with directional arrows (up, down, left, right).</p>
<p>4. Quick press "UP" button once to switch to P0.01 program.</p>	 <p>The control panel features a digital display showing 'P0.01'. Below the display are six indicator lights labeled STOP, RUN, FAULT, and two others. The control buttons include PRO/ESC, ENT/DAT, RUN, and STOP/RST, along with directional arrows (up, down, left, right).</p>
<p>5. Press "ENTER" button to be able to set up rated frequency. Press "&gt;&gt;" button to switch cursor location. Then, press "▲" or "▼" button to change value for nominal frequency. Until it shows correct nominal frequency, press "ENTER" button to confirm the setting.</p>	 <p>The control panel features a digital display showing '050.00'. Below the display are six indicator lights labeled STOP, RUN, FAULT, and two others. The control buttons include PRO/ESC, ENT/DAT, RUN, and STOP/RST, along with directional arrows (up, down, left, right).</p>



6. Quick press "▲" button once to switch to P0.02 program.

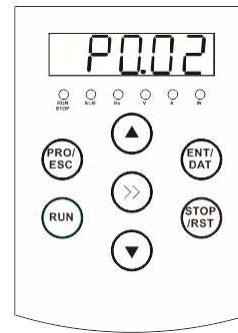

7. Press "ENTER" button to be able to set up nominal voltage of the water pump. Press ">>" button to switch cursor location. Then, press "▲" or "▼" button to change value for nominal voltage. Until it shows correct nominal voltage, press "ENTER" button to confirm the setting.



8. Quick press "▲" button once to switch to P0.03 program.



9. Press "ENTER" button to be able to set up nominal current of the water pump. Press ">>" button to switch cursor location. Then, press "▲" or "▼" button to change value for nominal current. Until it shows correct nominal current, press "ENTER" button to confirm the setting.



10. Then, all parameters of water pump are set up completely. Press "ESC/PROG" button to return to P0 level. Press "ESC/PROG" button again for 1 second to return to main interface.

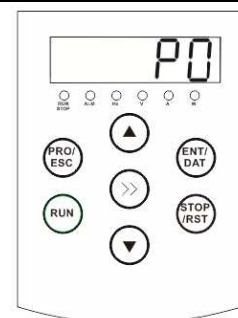

11. Turn on the inverter by pressing "RUN" button. Then, RUN/STOP LED will light up and display screen will show the output frequency.

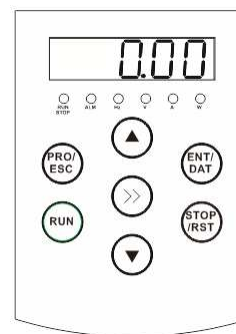

**NOTE:** If it's requested to have the inverter automatically turned on every morning, please set up program P4.01 as "1" in standby mode.

### Parameter Setting Table

○: This parameter can be modified no matter the inverter is in operation or off status.

⊙: This parameter can be modified only when inverter is turned off and it shows 0.00 Hz in display screen.

Program #	Description	Setting Range	Unit	Default Value	Note
P0 Parameter settings for the motor					
P0.00	Nominal power	10-15000	W	15000	⊙
P0.01	Nominal frequency	50/60	Hz	50	⊙
P0.02	Nominal voltage	323-506	V	380	⊙
P0.03	Nominal current	0.1-60	A	29	⊙
P0.04	Upper limit for frequency	Setting value in P0.05 – setting value in P0.01	Hz	50	⊙
P0.05	Low limit for frequency	6 – setting value in P0.04	Hz	10	⊙
P1 Over-current device on the motor and torque increasing					
P1.00	Maximum current limit	10-200	%	110	A multiple of nominal current ○
P1.01	Kp for max. current control	50-6000	None	1000	○
P1.02	Ki for max. current control	5-1000	None	100	○
P1.03	60S overload protection	110-250	%	150	⊙
P1.04	Overload protection on motor	110-250	%	200	⊙
P1.05	Voltage for torque increasing	0-10	%	0	Percentage of nominal voltage

Program #	Description	Setting Range	Unit	Default Value	Note
P2 PV DC voltage setting					
P2.00	Over DC voltage protection	Setting value in P2.01 - 800	V	800	⊙
P2.01	Under DC voltage protection	220 – Setting value in P2.00	V	220	⊙
P2.02	PV reference voltage	Setting value in P2.01 – setting value in P2.00	V	530	○
P3 Protection setting for the inverter of the water pump					
P3.00	Sleep mode while PV energy is weak	10-3600	S	120	○
P3.01	Sleep mode for dry running	10-7200	S	1200	○
P3.02	Allow dry pumping duration	1-3600	S	5	○
P3.03	Over-temperature fault on inverter	60-100	°C	85	⊙
P3.04	Over-temperature warning on inverter	10 – setting value in P3.02	°C	75	○
P3.05	Acceleration time for motor	1-3600	S	20	⊙
P3.06	Deceleration time for motor	1-3600	S	20	⊙
P4 Inverter operation mode setting					
P4.00	MPPT function enable/disable	0 : Disable. Control PV voltage in setting value of P2.02 1 : Enable	None	1	⊙
P4.01	Auto turn-on	0 : Disable 1 : Enable	None	0	⊙
P4.02	Dry-pumping protection enable/disable	0 : Disable 1 : Enable	None	1	○
P5 User password setting and restore to default setting					
P5.00	User password setting	0-9999	None	0	○
P5.01	Remote monitored device ID setting	1-247	None	1	○
P5.02	Restore to default setting	0 : No 1 : Yes	None	0	⊙

# Fault and Warning Code

All fault and warning codes can be reset by pressing "RST" button except for A06 and A10. When faults or warning occur, press "RST" button and the inverter will enter standby mode. Press "RUN" button to turn on the inverter for operation again.

After A02 or A03 warning occurs, the inverter will auto restart operation after a period of sleep mode. If pressing "RST" button during sleep mode, be sure to press "RUN" button again for operation.

## Fault Reference Code

Fault code	Fault type	Possible Cause
E01	Time out for BUS soft start	The resistor of soft start is broken.
E02	Relay fault	The Relay is broken.
E03	Over voltage in output	1. Inverter control is abnormal. 2. Detection is interfered.
E04	Over current in output	1. Output short circuited. 2. The motor is suddenly locked. 3. The motor is abnormal.
E05	Output voltage RMS High	Inverter control is abnormal.
E06	High PV voltage	1. PV input voltage is too high. 2. There is something wrong with voltage detection circuit.
E07	Current unbalance	1. Output phase loss 2. Output wire is short to the earth. 3. The motor is abnormal.
E08	Fan Locked	The fan is locked.
E09	Over Temperature	1. IGBT temperature is too high 2. The wire of IGBT temperature detection is not connected.
E10	Over current.	1. Output short circuited. 2. The motor is suddenly locked. 3. The motor is abnormal.
E11	Bus voltage over	1. Pump intrusion. 2. PV voltage is too high.
E12	Current detect fault	Current detection circuit is abnormal.
E13	Output voltage detect fault	Voltage detection circuit is abnormal.
E14	NTC0 damage	Internal temperature sensor for NTC is damaged.
E15	NTC1 damage or dis-connection	Fault occurs on temperature sensor circuits.

## Warning Reference Codes

Warning code	Warning type	Possible Cause
A01	PV input voltage is too low.	1. PV input voltage is too low. 2. Sunlight is too weak.
A02	Weak sunlight	Sunlight is too weak
A03	Dry running	1. Water level in the well is low. 2. Nominal power of motor is not setting.
A04	Overload	1. The motor is suddenly locked. 2. The pump head is too high. 3. Wrong current setting on the motor.
A05	Over current	1. The motor is suddenly locked. 2. Wrong current setting on the motor.
A06	EEPROM error	There is something wrong with EEPROM circuit.
A07	IGBT over temperature warning	Over temperature on IGBT.
A09	Over-temperature fault for environment	1. Environment temperature is beyond the upper limit (60°C). 2. The wire of environment temperature detection is not connected.
A10	Wrong parameter setting in the motor.	Wrong parameter setting in the motor.
A11	Water tank is full.	Water tank is full.
A12	Water tank is dry.	No water or water in low level in the water tower.
A13	Well is dry.	No water or water in low level in the well.
A14	Password verification is not complete.	No password is set up.

# SPECIFICATIONS

<b>MODEL</b>	<b>SP15K Revival</b>
<b>Maximum PV Array Power</b>	24000 W
<b>Rated Output Power</b>	15000 W
<b>PV INPUT (DC)</b>	
Nominal DC Voltage / Maximum DC Voltage	540 VDC / 800 VDC
Start-up Voltage	250 VDC
MPPT Voltage Range	250 VDC ~ 780VDC
Number of MPP Trackers	1
<b>OUTPUT</b>	
Nominal Voltage	3 x 380/400/415/440 VAC
Efficiency	> 97%
Nominal Output Current	29 A
Motor Type	Three-phase asynchronous motor
Frequency Precision	±0.2%
<b>PROTECTION</b>	
Full Protection	Phase lost, dry pumping, motor locked, weak sunlight, over-voltage, under-voltage, over-current, surge, over-temperature and short circuit protection
<b>PHYSICAL</b>	
Dimension, D X W X H (mm)	320 x 218 x 205
Net Weight (kgs)	6
Type of Mechanical Protection	IP20
<b>INTERACE</b>	
Communication Port	RS-232/RS-485
<b>ENVIRONMENT</b>	
Humidity	< 95% RH (No condensing)
Operating Temperature	Full load operation at -20°C~45°C Output de-rating at 46°C~60°C